

WINKELPROFILE

Wandstärke 2,5 und 3,0 mm

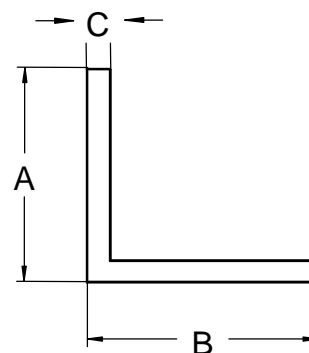

ARTIKEL	A	B	C
WI 1515	15	15	2,5
WI 2020	20	20	2,5
WI 2525	25	25	2,5
WI 3030	30	30	2,5
WI 3535	35	35	2,5
WI 4040	40	40	2,5
WI 5050	50	50	3,0
WI 6060	60	60	3,0
WI 1525	15	25	2,5
WI 1530	15	30	2,5
WI 2040	20	40	2,5
WI 2040	20	40	3,0
WI 2545	25	45	3,0
WI 2065	20	65	2,5
WI 2580	25	80	3,0
WI 3050	30	50	3,0
WI 4060	40	60	3,0
WI 5080	50	80	3,0
WI 60100	60	100	2,5
WI 60100	60	100	3,0
WI 80100	80	100	3,0

WINKELPROFILE mit abger. Ecken

Wandstärke 3,0 mm

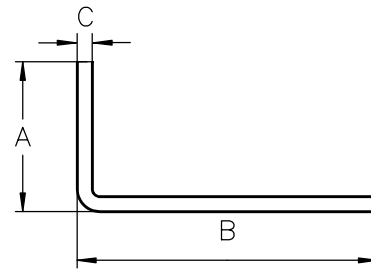

ARTIKEL	A	B	C
WIR 2020	20	20	3,0
WIR 3030	30	30	3,0
WIR 4040	40	40	3,0
WIR 5050	50	50	3,0
WIR 6060	60	60	3,0
WIR 7070	70	70	3,0
WIR 8080	80	80	3,0
WIR 9090	90	90	3,0
WIR 105105	105	105	3,0
WIR 4080	40	80	3,0
WIR 2090	20	90	3,0
WIR 20100	20	100	3,0
WIR 20130	20	130	3,0
WIR 20150	20	150	3,0
WIR 25120	25	120	3,0
WIR 25150	25	150	3,0
WIR 30160	30	160	3,0
WIR 40140	40	140	3,0
WIR 50100	50	100	3,0
WIR 50160	50	160	3,0
WIR 60150	60	150	3,0
WIR 70140	70	140	3,0
WIR 80160	80	160	3,0

WINKEL MIT ABGER. ECKEN

Wandstärke 2,0 bis 2,5 mm

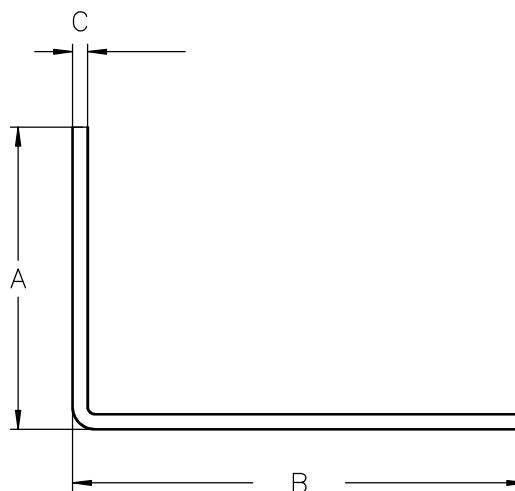

ARTIKEL	A	B	C
WIR 2020x2,0	20	20	2,0
WIR 3030x2,0	30	30	2,0
WIR 2040x2,0	20	40	2,0
WIR 2040x2,5	20	40	2,5
WIR 3050x2,0	30	50	2,0
WIR 4060x2,0	40	60	2,0
WIR 4060x2,5	40	60	2,5
WIR 5080x2,0	50	80	2,0
WIR 60100x2,0	60	100	2,0
WIR 60100x2,5	60	100	2,5

HOHLKAMMER- WINKEL

Stärke 6,0 mm

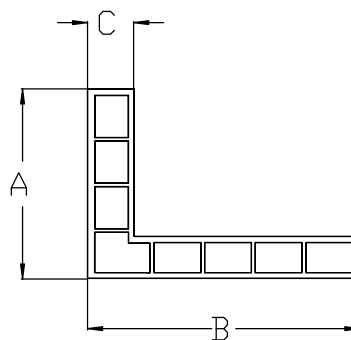

ARTIKEL	A	B	C
HWI 3540	35	40	6,0
HWI 3080	30	80	6,0
HWI 60100	60	100	6,0
HWI 80100	80	100	6,0
HWI 90110	90	110	6,0
HWI 110110	110	110	6,0

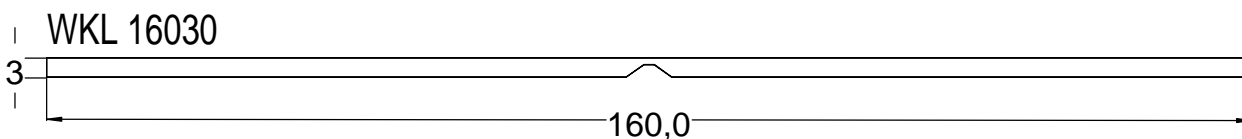
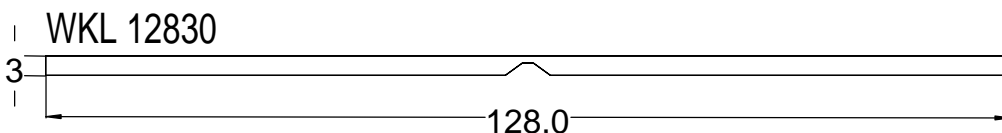
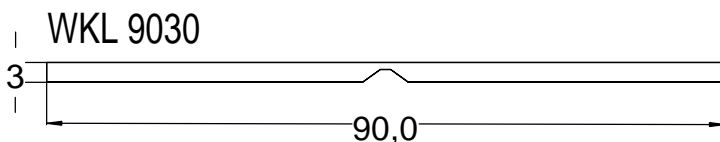
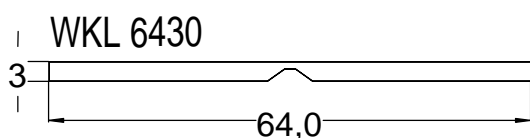
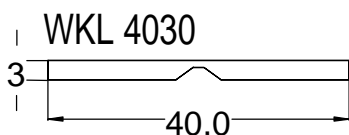

KLAPPWINKEL

Stärke 3,0 mm

KLAPPWINKEL Stärke: 1,8 mm

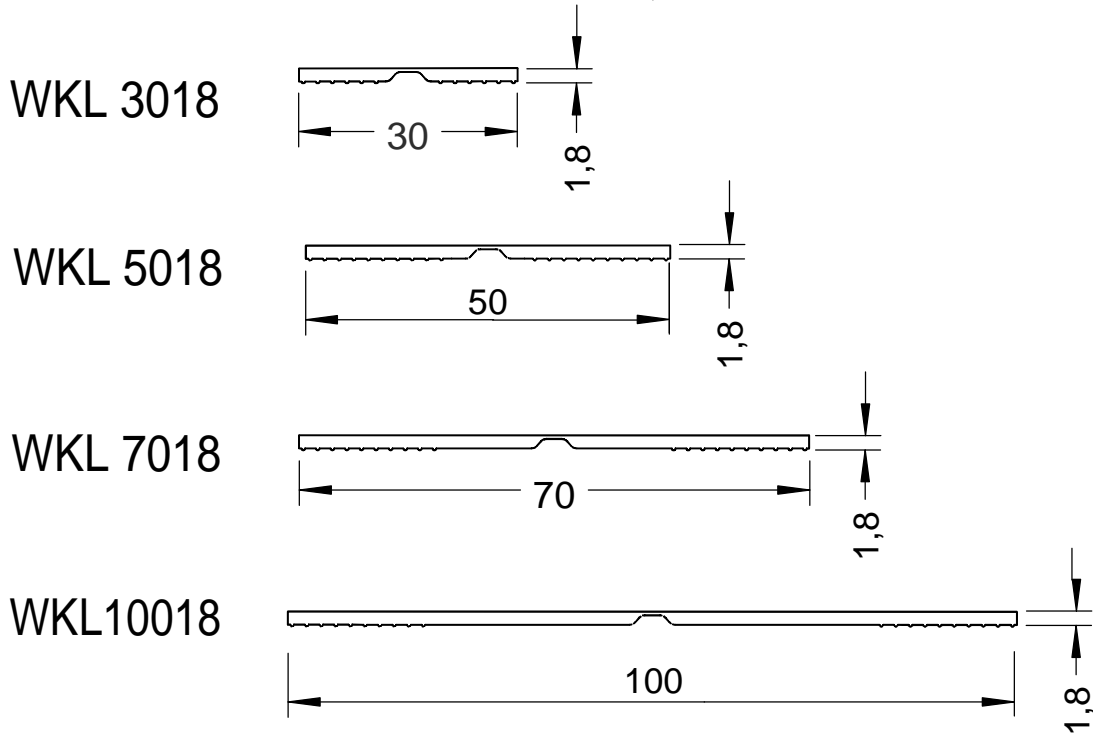

KLAPPWINKEL Stärke: 1,5 mm MIT SCHAUMKLEBER AUF ROLLE

